

USER MANUAL

SNIPER SCOPE

ZFM 6x42Z

MODEL 575

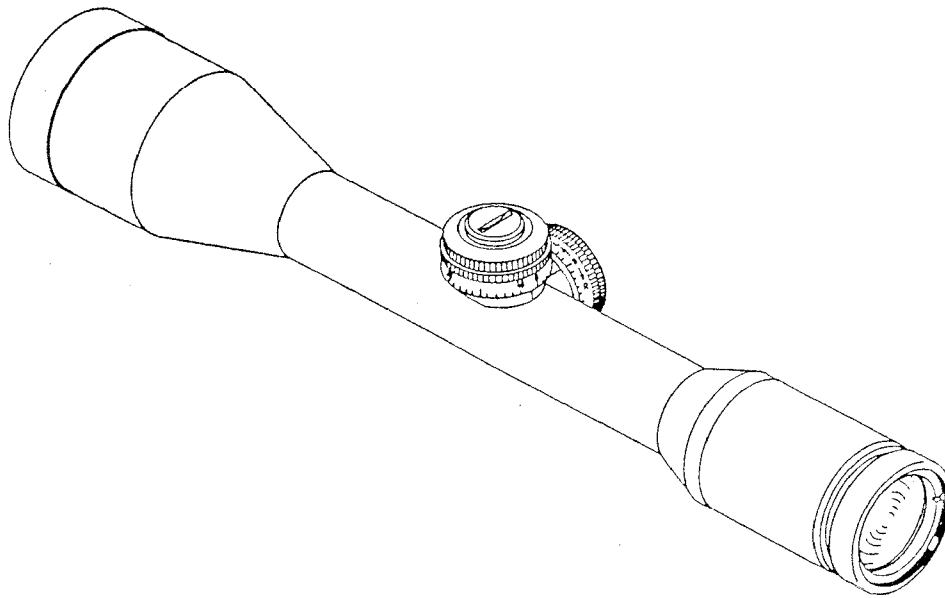

EDITION 1996

C O N T E N T S

1. General
2. Technical Data
3. Operation Instructions
4. Alignment to the Weapon
5. Care

1. GENERAL

Sniper Scopes are precision instruments subjected to the highest military demands. They should be treated carefully, not only when in use, but also when serviced or repaired in an optical workshop. Repairs should be carried out by skilled personnel only. An optical workshop requires a closed room, this room should be as dustfree as possible.

The Sniper Scope ZFM 6 x 42 Z is an optical aiming device with the following basic characteristics:

- * the target and the reticle pattern are always focused
- * the reticle pattern is centered to the field of view within the total adjustment range in elevation and windage
- * the image of the target is magnified six times
- * the line of sight can be adjusted according to ballistic data of ammunition, target distance and wind situation.

2. TECHNICAL DATA

Magnification	6 x
Field of view	4 degrees, 7 m / 100 m
Objective aperture	42 mm dia.
Exit pupil	7 mm dia.
Eye relief	80 mm
Dioptic adjustment	+/- 2.5 dpt
Parallax-free at	300 m
Resolution	10 arc sec
Light transmission	80 %
Centered reticle	
Elevation adjustment	100m to 800m, 0.25 mil/click
Windage adjustment	+/- 2 mils, 0.1 mil/click
Range for alignment	Elevation: +/- 3 mils Azimuth : +/- 10 mils
Ringmount	26 mm dia.
Operation temperature	-30 deg C to +55 deg C
Storage temperature	-40 deg C to +71 deg C
Dust and waterproof	
Design data	
Main tube	steel, burnished
Eyepiece	aluminium, black anodized
Painting	dull black
Weight	approx. 500 grams

3. OPERATION INSTRUCTIONS

NOTE: Prior of shooting, a check is to be made to insure that the scope correctly is mounted on the weapon !

3.1 Focusing

Focusing of the eyepiece is accomplished by turning the eyepiece (11). To focus optimally, proceed as follows:

- * turn the eyepiece counter-clockwise until it stops
- * look through the scope - the correct distance between eyepiece and eye is about 80 mm
- * turn the eyepiece clockwise until the image of the reticle pattern is sharply focused.

The dioptric correction range is +/- 2.5 dpt.

3.2 Elevation adjustment

Elevation adjustment (100m to 800m) is carried out with the elevation turret on the top of the scope.

One click corresponds to a shift of the line of sight of 0.25 mil. The elevation drum (7) is scaled and numbered in hectometers from 1 to 8.

3.3 Windage adjustment

The turret for windage adjustment (2) is placed on the right side of the scope and allows fine lateral correction of the point of impact in order to, e.g., correct for side wind. The middle adjustment point is when the figure "0" is opposite the reference index (10). Clockwise rotation of the windage turret (in the direction of "R") moves the point of impact to the right. Counter-clockwise adjustment (in the direction of "L") moves the point of impact to the left.

One click corresponds to 0.1 mil left or right. The total adjustment range is +/- 2 mils.

3.4 Aiming procedure

Aim to the target with the center of the reticle pattern.

- * the width of the horizontal central line corresponds to 0.15 mil
- * the width of the vertical line and the outer horizontal lines corresponds to 1.5 mils
- * the clear space between the arrow and the central horizontal line corresponds to 0.7 mil
- * the interval between the thick horizontal lines corresponds to 14 mils.

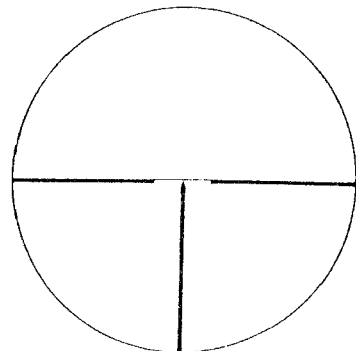

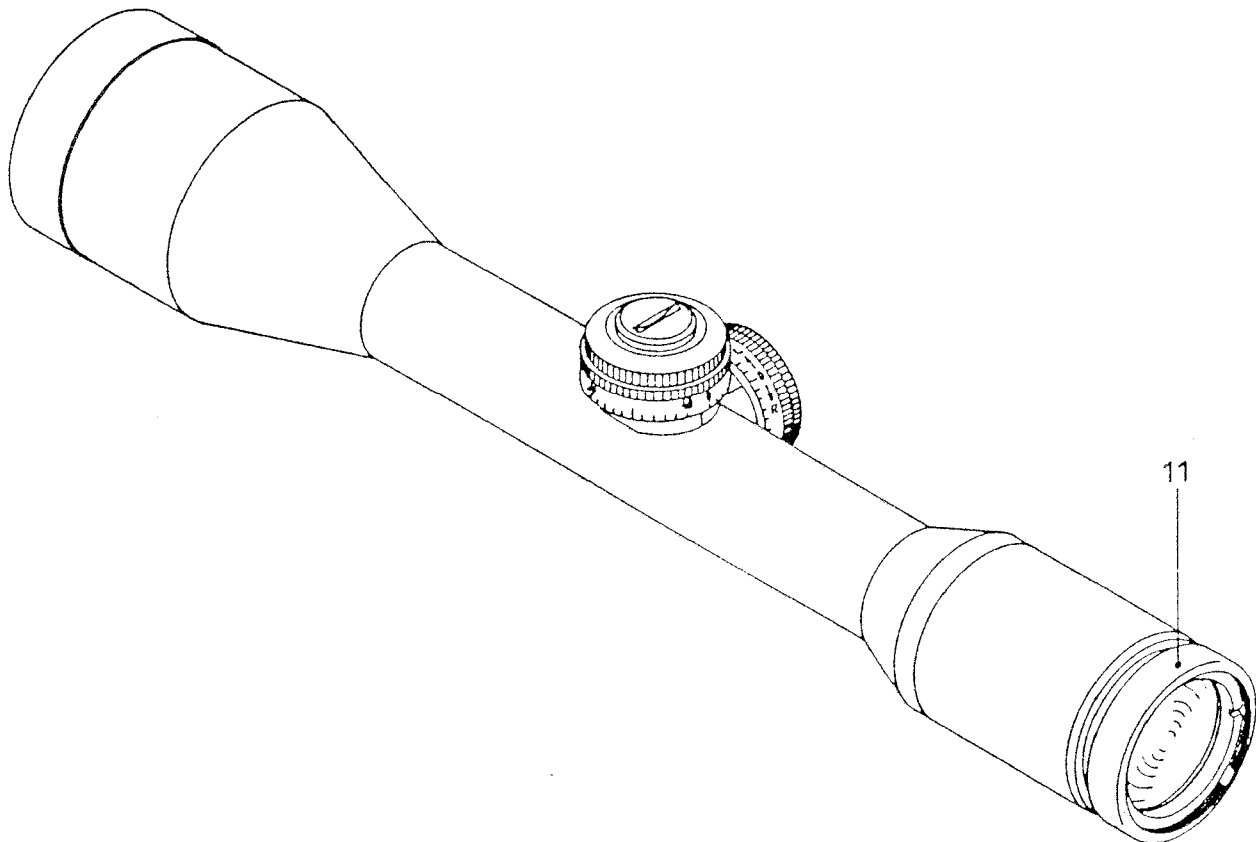
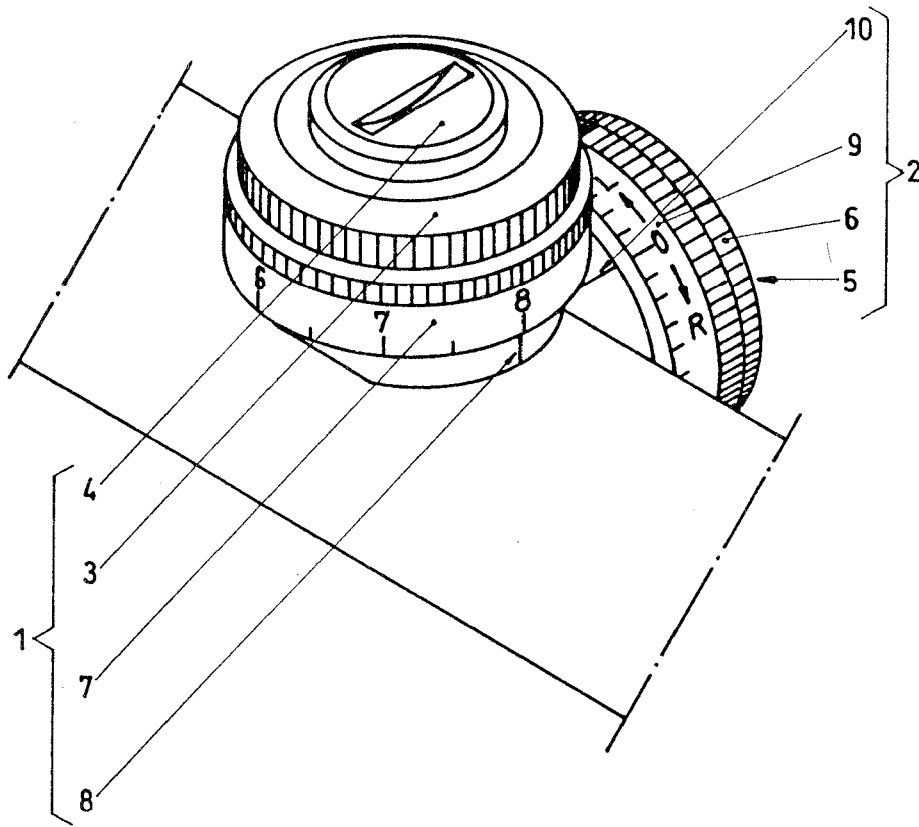

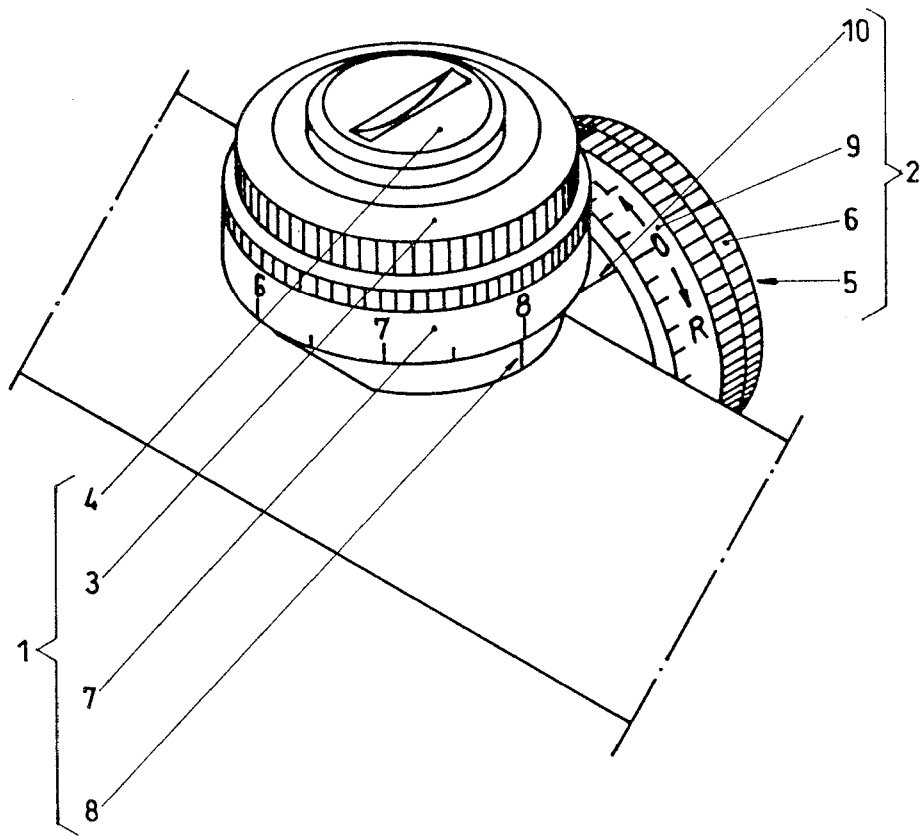

4. ALIGNMENT TO THE WEAPON

4.1 General

The ZFM 6x42 Z Sniper Scope is a precision instrument. To be able to exploit its outstanding features maximally, mounting and alignment should be carried out by qualified personnel only.

Alignment to the weapon is done by ranging to a target butt in a shooting range.

Correction of the point of impact of the bullet is made by means of the elevation and windage adjustment turrets.

NOTE: Prior to sighting in, a check is to be made to assure that the scope is correctly mounted to the weapon !

4.2 Alignment

1. Adjust the elevation turret (1) for the target distance, e.g. for 100 m; adjust the windage turret (2) to "0"
2. Shoot one round
3. a) The point of impact is too low:
turn the elevation turret clockwise - one click moves the point of impact 25mm/100m respectively 75mm/300m
- b) The point of impact is too high:
turn the elevation turret anti-clockwise - one click moves the point of impact 25mm/100m respectively 75mm/300m
- c) The point of impact is left of the center: turn the windage turret (2) clockwise (in direction of "R") - one click moves the point of impact 10mm/100m resp.30mm/300m
- d) The point of impact is right of the center: turn the windage turret anti-clockwise (in direction of "L") - one click moves the point of impact 10mm/100m resp.30mm/300m
4. Repeat steps 2. and 3. until the point of impact is correct
5. Hold the knurled knob (3) fixed, loose the coin screw (4) and turn the elevation scale drum (7) until the correct distance number is opposite the elevation reference index (8); retighten the coin screw (4).
NOTE: Knurled knob must not rotate during this procedure !
Hold the knurled knob (6) fixed, loose the coin screw (5) and turn the windage scale drum (9) until the "0" is opposite the windage reference index (10); retighten the coin screw (5).
NOTE: Knurled knob must not rotate during this procedure !
6. Shoot three rounds to check the alignment.

5. CARE

Keep all optical surfaces free of oil and grease. A dirty lens should be carefully cleaned first of all with a dust brush and then with an optical cleaning cloth or lens-cleaning tissue.

Dirt adhering lightly to metal surfaces should be removed with a clean and dry cloth (not an optical cleaning cloth !). Firmly adhering dirt should be removed using a moist (not wet !) cloth.