

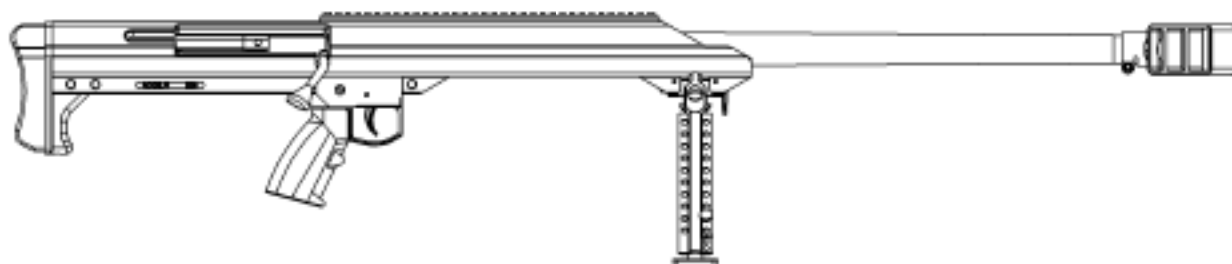

Model 99



Operator's Manual

October 13, 2006

USE OF THIS MANUAL

Before you handle the Model 99 rifle, read this manual in its entirety. It is important that you understand the principles of safe gun handling in general and the unique features of this rifle. This manual is not a substitute for training from a qualified instructor. Important safety topics are discussed in this chapter and throughout this manual. This manual should remain with the rifle and it should be transferred with the rifle to subsequent owners. It will be replaced at no cost by contacting the manufacturer.

This manual covers all variants of the Model 99. Technical specifications are subject to change without notice.

SAFETY GUIDELINES

WARNING

Failure to follow safety guidelines may cause injury or death.

Ammunition

Barrett does not condone the use of handloaded, remanufactured, or surplus ammunition. The use of clean, dry and properly stored commercially manufactured ammunition will preserve your warranty.

Safety distance

The .416 Barrett and .50 BMG cartridges are identical in construction to an ordinary centerfire rifle cartridge. Bullets fired from this rifle may travel as far as 5 miles. Make certain that you have an adequate backstop.

Hearing protection

Hearing loss is permanent. Hearing loss from gunfire is cumulative, but the noise from even one shot may cause permanent loss. Wear both ear plugs and ear muffs. It is also your responsibility to protect the hearing of those around you. The muzzle brake is integral to the design of your rifle and works to divert a large portion of a shot's blast rearward and to the side of the muzzle. Your rifle must not be fired without it. People and objects should not be in the vicinity of the muzzle brake because its blast consists of high pressure, high temperature gas. All spectators should use double hearing protection. The safest place for a spectator is directly behind the shooter.

Eye protection

Eye protection should be worn when both shooting and maintaining your rifle. It is normal for firing to generate airborne dust and debris. Glasses also protect you from scopes during recoil. Protect your eyes from solvents and uncaptured parts under spring pressure while performing maintenance on your rifle.

Assume every gun is loaded

Until you personally prove otherwise, treat every gun as if it were loaded. Do not trust your memory and do not take anyone else's word for it. Look and feel for an empty chamber. Do not trust the extractor to provide an empty chamber.

Beware of barrel obstructions

Ensure the barrel's bore is free of obstructions before you fire your rifle. Even the smallest obstruction such as a stuck patch or even grease will cause dangerously increased pressures that can rupture the barrel.

Use your muzzle brake

Your rifle was designed to be fired with the muzzle brake installed. Firing your rifle without the muzzle brake will subject your rifle and its accessories to damaging recoil. It could also cause the shooter to be injured.

Muzzle control

Always keep the muzzle pointed in a safe direction. Never allow your muzzle to point at anything that you do not intend to shoot.

Keep your finger off the trigger

Keep your finger off the trigger and out of the trigger guard until your sights are aligned on your target and you intend to fire.

Keep your safety on

Keep your safety on until your sights are aligned on your target and you intend to fire.

Identify your target and backstop

Before you pull the trigger, make certain of your target and what is beyond it. The rifle should never be fired at surfaces where bullets are likely to glance off in unpredictable directions.

Failure to fire

If your rifle fails to fire when you pull the trigger, do not lift the bolt handle to open the action. Keep the rifle pointed toward a safe area and wait 2 minutes. If a hangfire (slow ignition) has occurred, the round will probably fire within two minutes. If the round does not fire, remove and inspect the cartridge. If the primer is indented properly, discard it in a safe manner. If the primer is lightly dented, refer to the troubleshooting chart in this manual.

Maintain your rifle properly

Performing proper maintenance, as outlined in this manual, insures that your rifle will be safe to shoot and will perform to design specification for many years. Alterations, modifications or adjustments may damage your rifle, make it unsafe to fire and will void warranty claims.

Store your rifle safely

Even though your rifle represents a significant financial investment, the greatest value in keeping it secured is preventing it from falling into the hands of a child, a careless adult, or a thief. It is your responsibility to take every reasonable precaution to secure your rifle.

Alcohol, medications and drugs

Do not handle or operate your rifle under the influence of alcohol, medication or drugs.

WARRANTY AND SERVICE

Barrett Firearms Manufacturing Inc. (BFMI), warrants that this firearm was manufactured free of defects in materials and workmanship. For one year from the date of purchase by the original owner, BFMI agrees to correct any defect in this firearm for the original purchaser by repair or replacement with the same or comparable model.

BFMI will not be responsible for injury, death, or damage to property resulting from either intentional or accidental discharge of this firearm or from its function when used for purposes or subjected to treatment for which it was not designed. BFMI will not honor claims involving this firearm which result from careless or improper handling, unauthorized adjustment or parts replacement, corrosion, neglect, the use of the wrong caliber ammunition, or the use of other than commercially manufactured ammunition in good condition, or any combination thereof. BFMI will not honor claims involving this firearm when such claims are made by the second or subsequent owner.

If you need factory service, whether made under warranty or not, please contact BFMI for instructions on how to have your gun repaired.

Barrett Firearms Manufacturing Inc.
P.O. Box 1077
Murfreesboro, TN 37133-1077
615-896-2938

www.barrettrifles.com

Your Responsibility

Your Barrett rifle is well-engineered and manufactured to the highest standards. It was proof-fired and carefully inspected before it was packaged and shipped from our factory. Its safe use depends on you alone. You are the ultimate safety device. Much like other mechanical devices, such as electric power tools, gas-powered lawn equipment, and automobiles, your rifle is safe unless handled in an irresponsible or uneducated manner.

TABLE OF CONTENTS

Use of the manual	2
Safety	2-4
Warranty and service	5
Table of contents	6
Specifications	7
Contents	8
Function	8
Break-in	8
Loading	9-10
Unloading and clearing	11
Disassembly and assembly	12
Major components	12
Disassembly into major components	13-14
Reassembly of major components	14
Removal of firing pin assembly	15-16
Removal of ejector and extractor	17-18
Installation of ejector and extractor	19-20
Cleaning and lubrication	21
Corrosive ammunition	22
Blank	23
Troubleshooting	24
Exploded views and parts lists	25-28
Blank	29

SPECIFICATIONS

BARRETT MODEL 99

CALIBERS .416 Barrett or .50 BMG

BARREL LENGTHS	OVERALL LENGTH	WEIGHT
32 inches heavy	50 inches	25 pounds
29 inches fluted	47 inches	23 pounds
25 inches fluted	43 inches	20 pounds

TWIST RATE	.416 Barrett	1 turn in 12 inches, right hand
	.50 BMG	1 turn in 15 inches, right hand

SAFETY Manual, thumb lever

SAFETY RANGE NEEDED 5 miles

SCOPE RAIL Steel, parallel with bore, M1913 style, 13.75 inches long

CARRYING CASE LENGTH	53 inches
CARRYING CASE WIDTH	16 inches
CARRYING CASE DEPTH	6 inches
CARRYING CASE WEIGHT	24 pounds

SCOPE AND RINGS WEIGHT 2.0 pounds (typical)

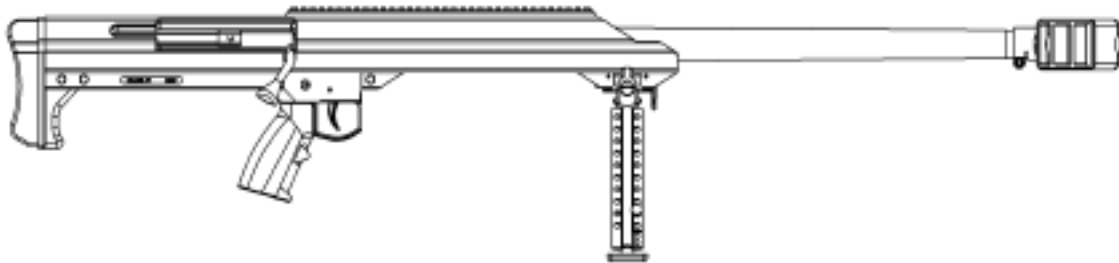

Figure 1. Model 99 with 32" heavy barrel

CONTENTS

Your Model 99 rifle includes the following:

- Rifle with bipod
- Watertight and airtight carrying case
- Operator's manual

Your rifle may have included a rifle scope and rings. It may have also included cleaning fluids and a cleaning kit.

The rifle is shipped from the factory fully assembled. (Figure 2.)

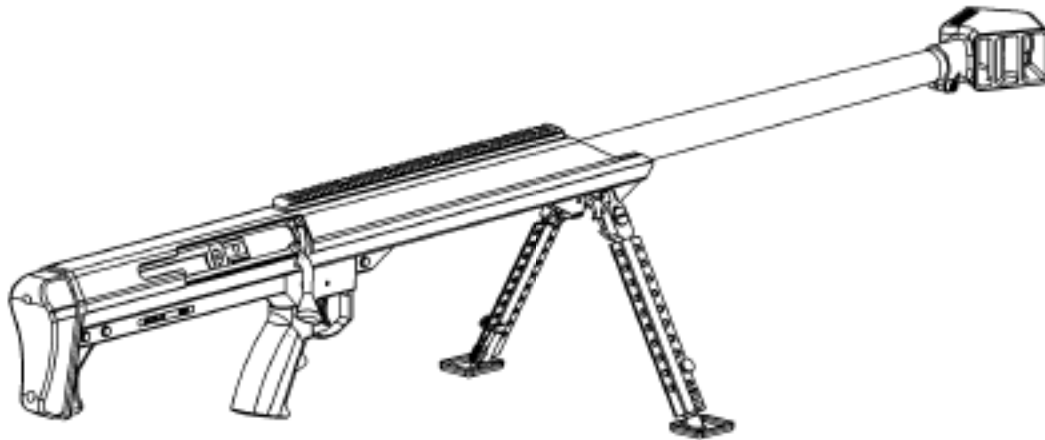

Figure 2. Fully assembled rifle.

FUNCTION

The Model 99 is a single shot, bolt action rifle. The shooter manually loads one single cartridge. The firing pin assembly is cocked when the bolt handle is raised. The bolt is retained in the receiver and is equipped with an extractor to remove a cartridge or shell casing. A manually controlled safety prevents or permits trigger movement.

BREAK-IN PROCEDURE

Because individual barrels, powder, primer and bullet combinations vary widely and because shooters have strongly held personal opinions on the subject, Barrett does not offer a specific procedure for barrel break-in. Barrett does recognize that a clean barrel shoots better. Barrett also recommends that you do not overheat your barrel, especially your new barrel. Experience has shown that the bore becomes less prone to fouling over time and that accuracy may increase as this occurs.

LOADING

1. Rotate the safety lever to the "SAFE" (lever horizontal) position. (Figure 3.)

WARNING

Do not attempt to force a cartridge into the chamber by forcing the bolt closed. If the bolt will not close easily, remove the cartridge and examine it for damage or defects. Check the chamber for obstructions.

2. With the rifle pointed in a safe direction, lift the bolt handle and draw it to the rear (Figure 4, step A.). Insert a cartridge into the ejection port (Figure 4, step B.) Push the bolt handle fully forward (Figure 4, step C.) and then downward (Figure 4, step D.).

WARNING

The shooter must be positioned directly behind the rifle with the recoil pad held firmly against the shoulder. Firing the rifle in any other position could result in injury by contact with the rifle or rifle scope.

WARNING

Do not fire the rifle unless all three assembly pins are secured in place. Severe injury will result by firing the rifle without these pins in place.

3. The rifle may now be fired by rotating the safety lever to the "FIRE" (lever vertical) position (Figure 5.) and then pulling the trigger.

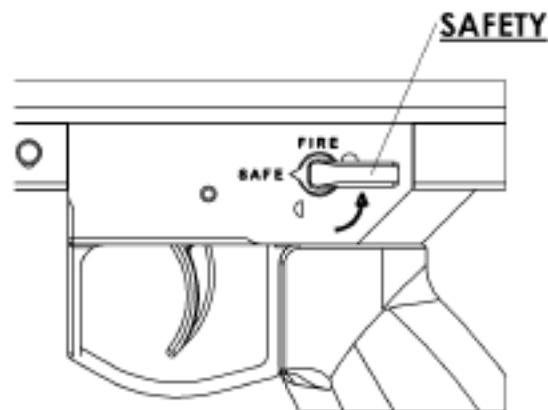

Figure 3. Safety lever to "SAFE".

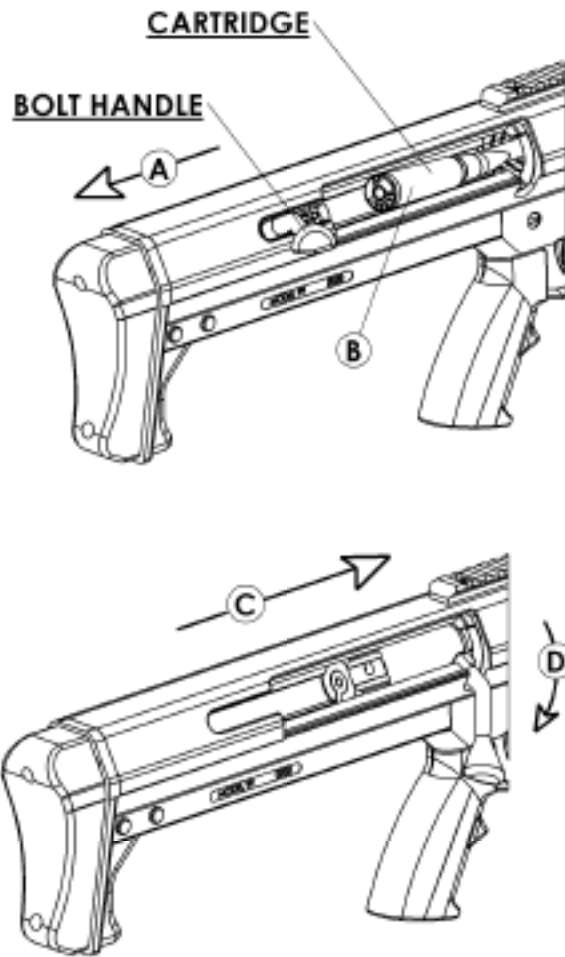

Figure 4. Loading sequence.

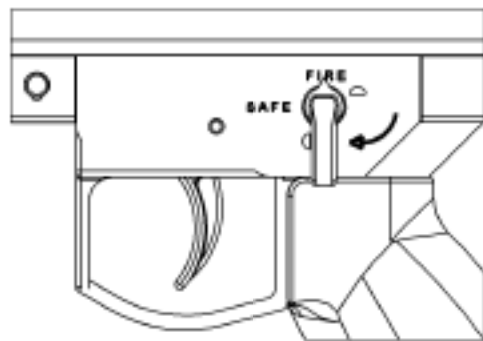

Figure 5. Safety lever to "FIRE".

UNLOADING AND CLEARING

1. Place the safety lever in the "SAFE" position.
2. Lift the bolt handle upward and pull it to the rear to eject a chambered cartridge or spent shell casing.
3. With the bolt pulled fully to the rear, look into the chamber to make sure that the cartridge or shell casing has been removed. Insert a finger into chamber to verify the empty chamber.

DISASSEMBLY AND ASSEMBLY

WARNING

Unload and clear the rifle before disassembly. Following the disassembly steps will release the firing pin. If a cartridge is in the chamber it will fire. Ensure no live ammunition is present during disassembly or assembly.

The rifle may be disassembled into 5 major components by removing 3 assembly pins and 1 bipod assembly pin. (Figure 6.)

Major components

- Receiver assembly (1)
- Buttplate assembly (2)
- Trigger housing assembly (3)
- Bolt assembly (4)
- Bipod assembly (5)

Assembly pins

- Assembly pins (6)
- Bipod assembly pin (7)

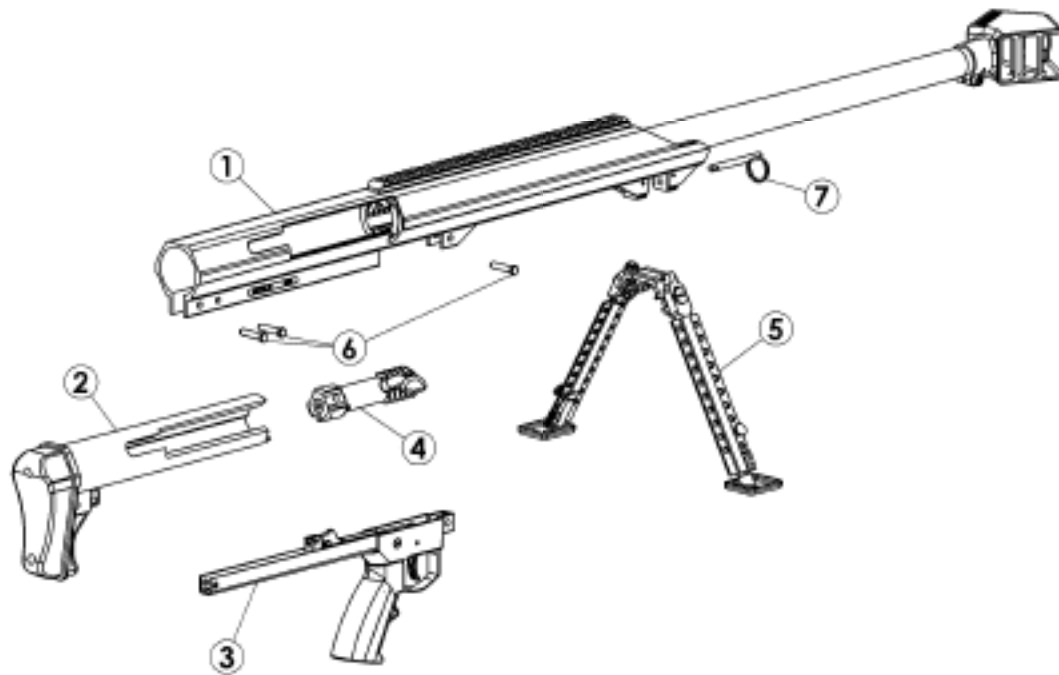

Figure 6. Major components.

Disassembly into major components

1. Deploy bipod legs to let the rifle rest on the bipod feet and buttplate assembly.
2. Raise the bolt handle but do not retract it from the barrel. (Figure 7, step A.) Remove the two rear assembly pins and the forward assembly pin. (Figure 7, step B.)

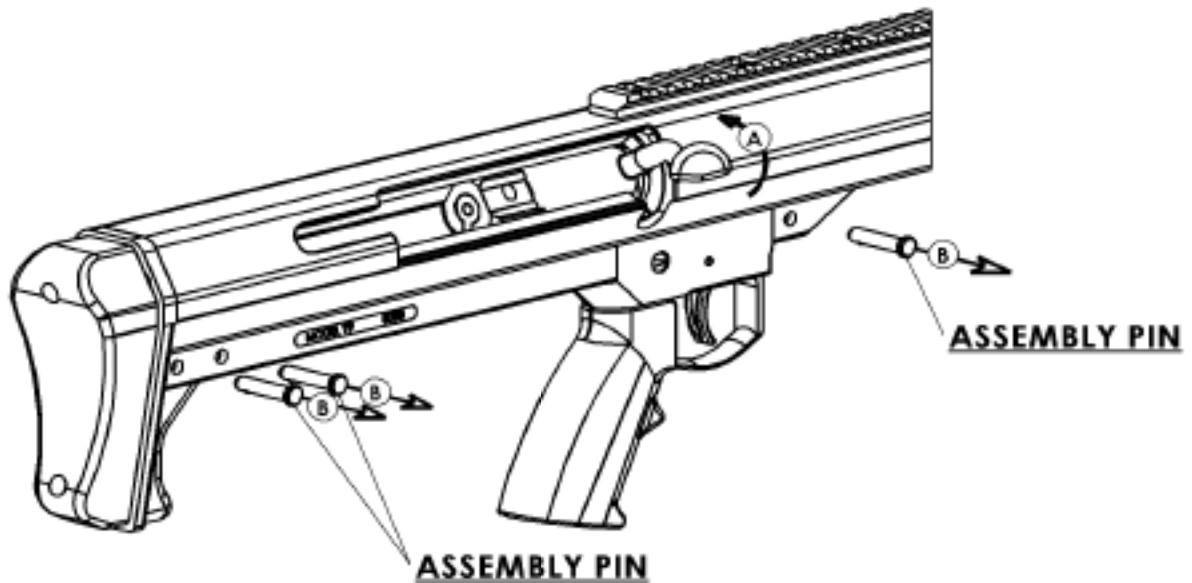

Figure 7.

3. Remove the trigger housing assembly by pulling the pistol grip downward out of the receiver. (Figure 8.)

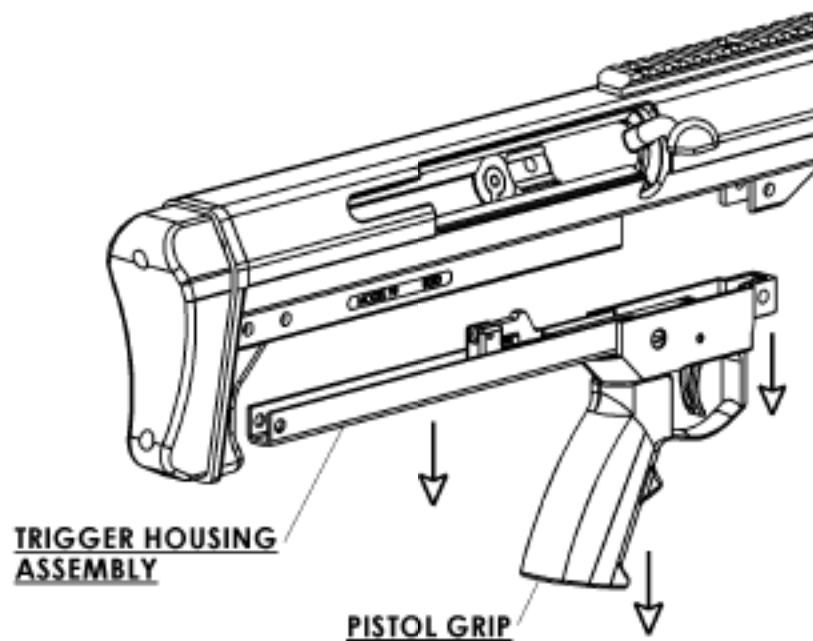

Figure 8.

NOTE

No further disassembly of the trigger housing assembly is recommended or necessary for maintenance.

NOTE

The firing pin assembly is cocked by raising the bolt handle. Disassembly is facilitated by removing the bolt assembly with its firing pin assembly cocked. The firing pin assembly can be accidentally uncocked by twisting the buttplate assembly as it is being removed. If this occurs, the firing pin assembly may be recocked while the bolt assembly remains in the receiver assembly. Capture the cocking piece shroud with the end of the buttplate assembly and twist the buttplate assembly clockwise 1/4 of a turn to recock the firing pin assembly. (See figure 6, parts 2 and 4.)

4. Without twisting, pull the buttplate assembly rearward to remove it from the receiver assembly.
5. Grasp the bolt handle and withdraw it from the barrel. Orient the bolt so that the locking lugs will pass through the cartridge feed and ejection port. Remove the bolt from the receiver.
6. Lift the front of the receiver to remove the gun's weight from the bipod legs. Pull the bipod assembly pin forward and remove bipod.

Reassembly of major components

Major components are assembled in reverse order of disassembly.

Removal of firing pin assembly from bolt assembly

NOTE

The firing pin assembly must be cocked to enable assembly pin insertion into the cocking piece shroud. The firing pin assembly is cocked when the cocking piece is outside of the cam slot. (See Figure 9.)

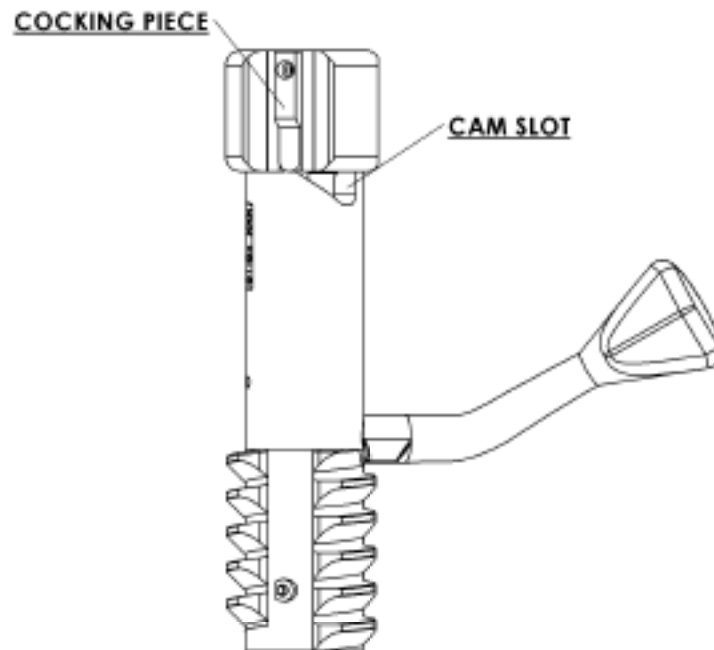

Figure 9. Cocked firing pin assembly.

1. Insert an assembly pin into the hole in the cocking piece shroud. The assembly pin may require lubrication and rotating as the pin is inserted. (Figure 10, step A.) This locks together the cocking piece shroud and the firing pin assembly.

WARNING

Do not remove the assembly pin from the cocking piece shroud while the firing pin assembly is removed from the bolt. The firing pin spring is under heavy load. Serious injury can occur if the assembly pin is removed.

2. Grasp the bolt handle. Turn the cocking piece shroud counter-clockwise to unscrew it from the bolt assembly. (Figure 10, step B.)

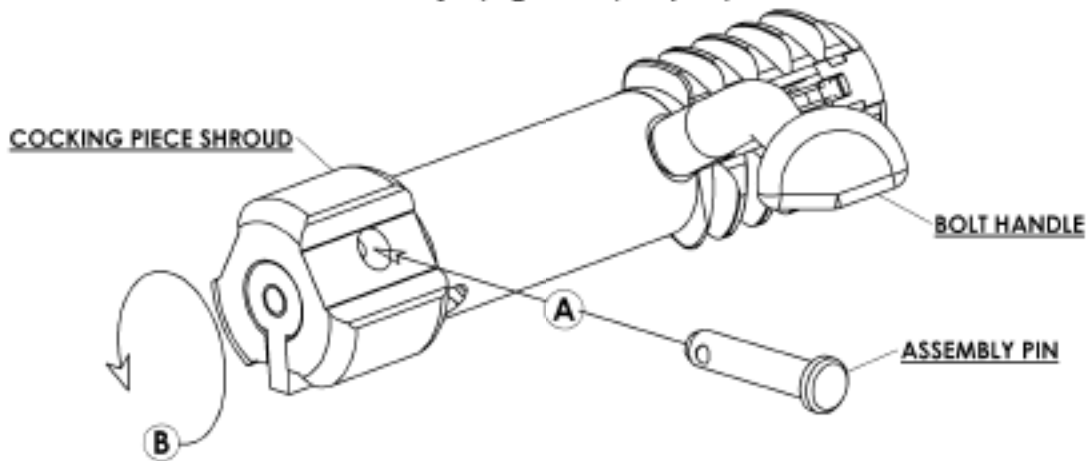

Figure 10.

3. Separate the firing pin assembly from the bolt assembly. (Figure 11.)

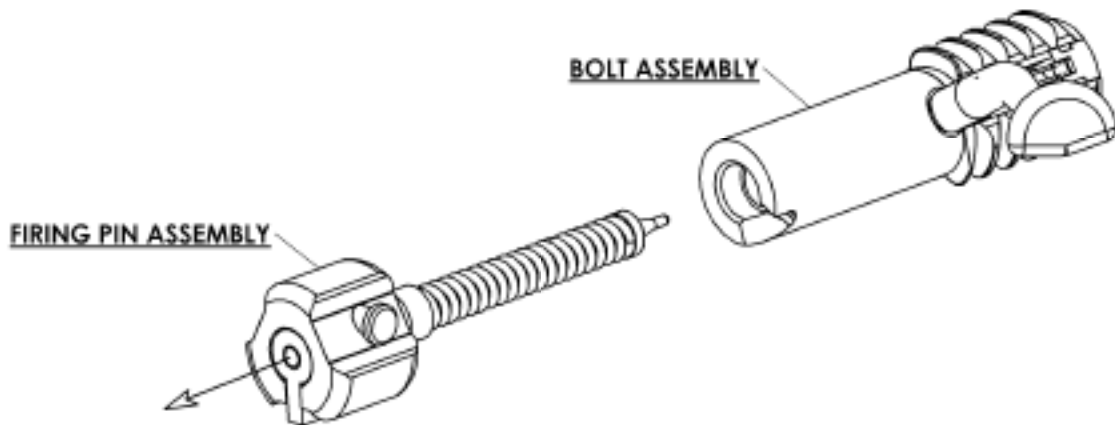

Figure 11.

NOTE

No further disassembly of the firing pin assembly is recommended or necessary for maintenance.

Installation of firing pin assembly into bolt assembly

Installation of the firing pin assembly into the bolt assembly is in the reverse order of its removal.

Removal and replacement of ejector and extractor

WARNING

The ejector is under spring pressure and is held in place by the ejector pin. Wear safety glasses when removing the ejector pin.

NOTE

Removal and replacement of the ejector pin requires the use of a hammer and a 3/32 pin punch. It is also useful to have a shell casing.

NOTE

The extractor, ejector and their springs are not likely to fail. If the rifle fails to extract or eject, rule out other causes before attempting this procedure. It is not necessary to remove either the extractor or the ejector for routine maintenance. Their removal is to facilitate parts replacement only. If you are not confident in your skills, Barrett Manufacturing will perform this service for a modest fee.

Ejector removal

1. Hold the bolt face firmly against a flat work surface. Drive the ejector pin out of the bolt with a 3/32 punch. (Figure 12, step A.) The ejector and ejector spring will escape from the bolt after the punch is retracted from the ejector pin hole.
2. Lift the bolt from the work surface and remove the ejector and ejector spring. (Figure 12, step B.)

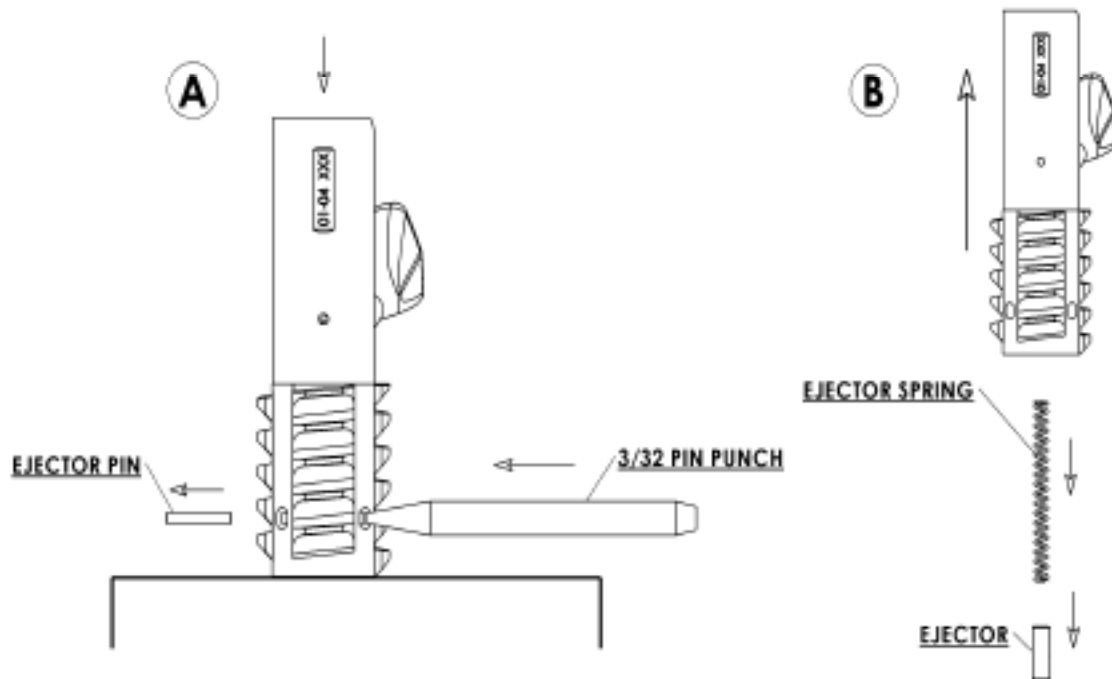

Figure 12.

Extractor removal

1. Using a 3/32 or smaller punch, gently lift the end of the extractor spring away from the extractor. Lift the spring just enough for it to clear the extractor. (Figure 13.)

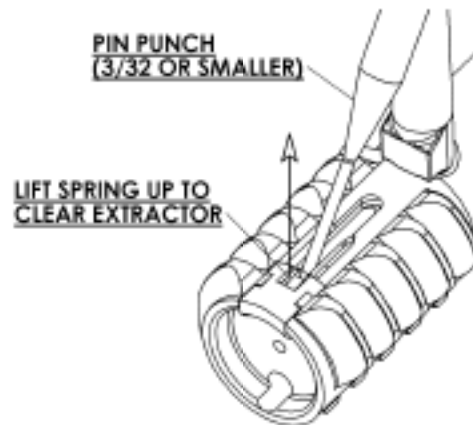

Figure 13.

2. Slide the extractor spring forward over the extractor until it is clear of the bolt recess. Remove the spring. (Figure 14.) Note that the end of the extractor spring is bent slightly toward the extractor.

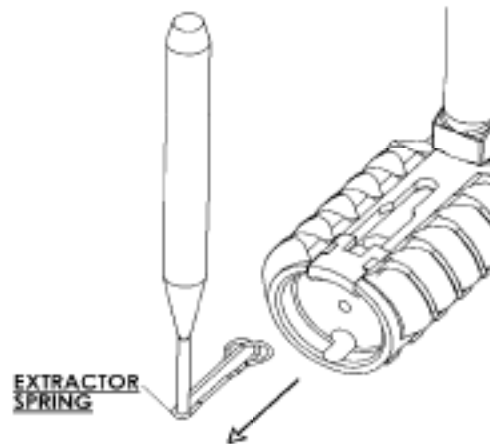

Figure 14.

3. Lift the extractor out of its recess in the bolt. (Figure 15.)

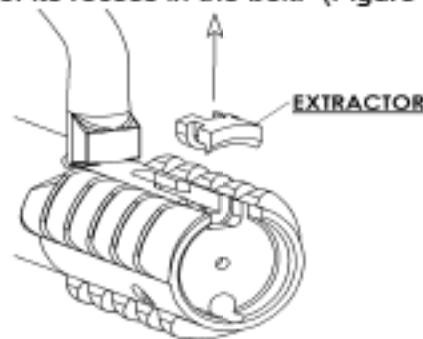

Figure 15.

Extractor installation

The installation of the extractor is in reverse order of its removal.

Ejector installation

1. Place the ejector spring in the ejector spring hole. (Figure 16, step A.) The spring is bi-directional.
2. Place the ejector in the ejector hole. (Figure 16, step B.) Orient the ejector so that the ejector's pin slot is facing toward the bolt.

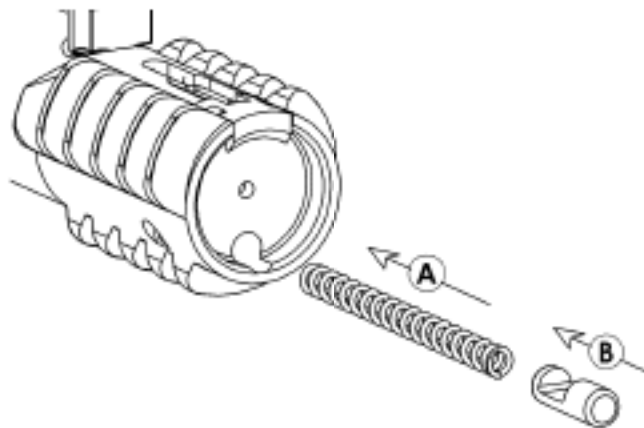

Figure 16.

3. Hook the rim of a shell casing under the extractor. Use the opposite side of the shell casing to force the ejector flush with the bolt face. (Figure 17.)

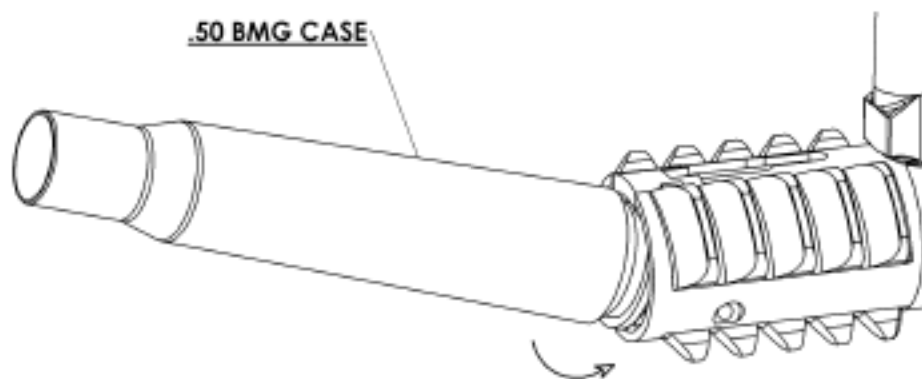

Figure 17.

4. Looking through the bolt's ejector pin hole, confirm that the ejector's pin slot is oriented so that the ejector pin hole is clear. While depressing the ejector with a cartridge case, insert a punch through one side of the ejector pin hole leaving room for the ejector pin to be started from the opposite side. (Figure 18, step A.) The punch holds the ejector in place until the ejector pin has been started from the opposite side. (Figure 18, step B.) With a 3/32 punch, finish driving the ejector pin until it is flush with the bolt's ejector pin recess.

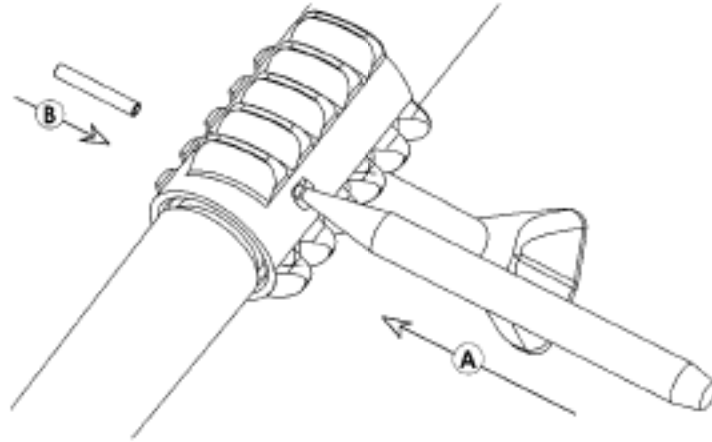

Figure 18.

CLEANING AND LUBRICATION

WARNING

Unload and clear the rifle before cleaning.

CAUTION

Do not insert cleaning rods through the muzzle. The barrel crown could be damaged which would severely degrade the accuracy of the rifle.

CAUTION

To protect the rifle from corrosion, the rifle and the interior of the carrying case should be moisture free before the rifle is placed in the carrying case for storage.

Cleaning procedure

1. The rifle should be cleaned and lubricated after each shooting session. Regular cleaning prevents the corrosive effects of moisture.
2. Apply cleaning solvent to a chamber brush and clean the chamber. Barrett Heavy Bore Cleaner is recommended.
3. Apply cleaning solvent to a bore brush and clean the bore. Barrett Heavy Bore Cleaner is recommended.
4. Clean the muzzle brake with a stiff plastic brush and bore solvent. It is best to clean the muzzle brake at the same time the barrel is being cleaned as the bore solvent will help loosen the carbon build-up on its interior walls.
5. Clean the bolt face with bore solvent. Use a stiff plastic brush to remove carbon from both the extractor and the ejector. Depress the ejector and extractor by hand to test their smooth function.
6. Use dry patches as necessary to remove cleaner from the bore and chamber.
7. Clean the remainder of the rifle with cotton-tipped swabs, general-purpose brushes and rags. Make sure all metal surfaces are coated with preservative oil.

Corrosive ammunition cleaning procedure

CAUTION

Barrett does not recommend shooting corrosive ammunition. Shooting corrosive ammunition may damage your firearm. Damage due to firing corrosive ammunition is easy to detect and is not covered under the warranty agreement.

CAUTION

Rust will begin to form on bare metal resulting from the hot water rinse unless rust preventative or light oil is applied immediately.

If you have been forced by necessity or have accidentally fired corrosive ammunition, the following specialized cleaning procedure applies.

1. **Cleaning.** Immediately after firing the corrosive ammunition, thoroughly scrub the bore and bolt face with very hot soapy water or cleaner specifically designed for corrosive ammunition.
2. **Rinsing and drying.** When the metal is clean, rinse the surfaces with very hot water. Wipe off excess moisture. The residual heat in the metal will evaporate most water droplets.
3. **Protecting.** Either continue cleaning the rifle using procedures specified for non-corrosive ammunition, or if temporary transportation or storage is necessary, immediately coat all surfaces with rust preventative.

(This page intentionally blank.)

TROUBLESHOOTING

MALFUNCTION	CAUSE	CORRECTIVE ACTION
1. Failure to chamber and lock	<ol style="list-style-type: none"> 1. Damaged cartridge 2. Dirty or obstructed chamber 	<ol style="list-style-type: none"> 1. Remove and replace cartridge 2. Clean chamber
2. Failure to fire	<ol style="list-style-type: none"> 1. Faulty ammunition (Primers dented in center of sufficient depth to fire) 2. Cocking piece shroud not properly installed in bolt 3. Cocking piece is dragging 4. Firing pin or firing pin spring broken or damaged 5. Bolt handle not down fully 	<ol style="list-style-type: none"> 1. Replace ammunition 2. Assemble properly 3. Clean and lubricate cocking piece 4. Return complete bolt assembly for repair 5. Ensure bolt handle is down fully
3. Failure to extract	<ol style="list-style-type: none"> 1. Broken or worn extractor 2. Broken or worn extractor spring 3. Extractor not moving freely 4. Dirty ammunition or chamber 5. Broken case rim 	<ol style="list-style-type: none"> 1. Replace extractor 2. Replace extractor spring 3. Clean extractor, extractor spring, and recess 4. Clean chamber and ensure ammunition is clean 5. Clear with cleaning rod
4. Failure to eject	<ol style="list-style-type: none"> 1. Broken or worn ejector 2. Broken or worn ejector spring 3. Ejector not moving freely 	<ol style="list-style-type: none"> 1. Replace ejector 2. Replace ejector spring 3. Clean ejector, ejector spring and recess
5. Very hard recoil	<ol style="list-style-type: none"> 1. Faulty or hot ammunition 2. Muzzle brake missing 3. Improper shooter position 	<ol style="list-style-type: none"> 1. Replace ammunition, cool if hot 2. Consult with Barrett for instructions 3. Firmly shoulder the buttstock

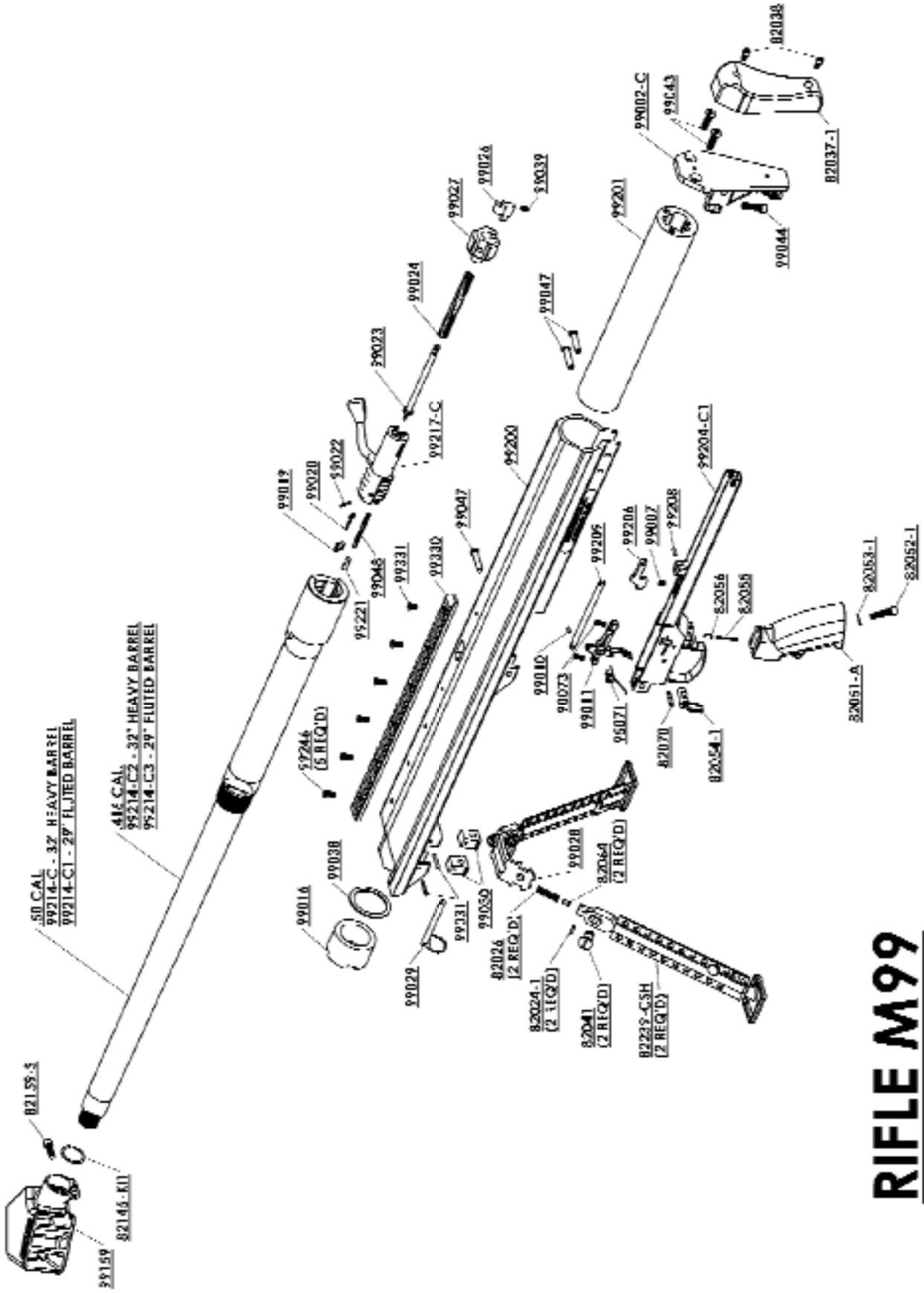

RIFLE M99

Model 99 Parts List
(Factory consultation required for part numbers preceded by "**")

PART NO.	DESCRIPTION	QTY.	PART NO.	DESCRIPTION	QTY.
82024-1	BIPOD PIN	2	99027	COCKING PIECE SHROUD	1
82028	BIPOD SPRING	2	99028	BIPOD YOKE	1
82037-1	RECOIL PAD	1	99029	BIPOD ASSEMBLY PIN	1
82038	RECOIL PAD SCREW	2	99030	YOKE MOUNT	2
82041	BIPOD SCREW	2	99031	YOKE MOUNT PIN	2
82051-A	PISTOL GRIP	1	*99038	BARREL WASHER	1
82052-1	PISTOL GRIP SCREW	1	99039	FIRING PIN LOCK SCREW	1
82053-1	PISTOL GRIP WASHER	1	99043	BUTTPATE BACK SCREW	2
82054-1	SAFETY	1	99044	BUTTPATE FRONT SCREW	1
82055	SAFETY SPRING	1	99047	ASSEMBLY PIN	3
82056	SAFETY DETENT	1	99048	EJECTOR SPRING	1
82064	BIPOD DETENT	2	99159	MUZZLE BRAKE	1
82070	TRIGGER HOUSING PIN	1	*99200	RECEIVER	1
82145-KIT	MUZZLE BRAKE SHIM KIT	1	*99201	BOLT GUIDE	1
82159-S	MUZZLE BRAKE SCREW	1	99204-C1	TRIGGER HOUSING COMPLETE	1
82239-CSH	BIPOD LEG	2	99206	SEAR PIVOT	1
*90073	TRIGGER OVERTRAVEL SCREW	2	99208	SEAR PIVOT PIN	1
95071	TRIGGER SPRING	1	99209	SEAR LINK	1
99002-C	BUTTPATE COMPLETE	1	*99217-C	BOLT COMPLETE	1
99007	SEAR PIVOT SPRING	1	99221	EJECTOR	1
*99010	SEAR LINK PIN	1	99246	SCOPE BASE SCREW	5
*99011	TRIGGER	1	99330	SCOPE BASE	1
*99016	BARREL NUT	1	99331	REAR SCOPE BASE SCREW	1
99019	EXTRACTOR	1	*99214-C	BARREL COMPLETE .50, 32"	1
99020	EXTRACTOR SPRING	1	*99214-C1	BARREL COMPLETE .50, 29" FLUTED	1
99022	EJECTOR PIN	1	*99214-C2	BARREL COMPLETE .416, 32"	1
99023	FIRING PIN	1	*99214-C3	BARREL COMPLETE .416, 29" FLUTED	1
99024	FIRING PIN SPRING	1			
99026	COCKING PIECE	1			

Model 99H Parts List

(Factory consultation required for part numbers preceded by "****")

PART NO.	DESCRIPTION	QTY.
82024-1	BIPOD PIN	2
82026	BIPOD SPRING	2
82037-1	RECOIL PAD	1
82041	BIPOD SCREW	2
82051-A	PISTOL GRIP	1
82052-1	PISTOL GRIP SCREW	1
82053-1	PISTOL GRIP WASHER	1
82054-1	SAFETY	1
82055	SAFETY SPRING	1
82056	SAFETY DETENT	1
82064	BIPOD DETENT	2
82070	TRIGGER HOUSING PIN	1
82145-KIT	MUZZLE BRAKE SHIM KIT	1
82159-S	MUZZLE BRAKE SCREW	1
82239-CSH	BIPOD LEG	2
*90073	TRIGGER OVERTRAVEL SCREW	2
95071	TRIGGER SPRING	1
99002-C	BUTTPATE COMPLETE	1
99007	SEAR PIVOT SPRING	1
*99010	SEAR LINK PIN	1
*99011	TRIGGER	1
99019	EXTRACTOR	1
99020	EXTRACTOR SPRING	1
99022	EJECTOR PIN	1
99023	FIRING PIN	1
99024	FIRING PIN SPRING	1
99026	COCKING PIECE	1
99027	COCKING PIECE SHROUD	1

PART NO.	DESCRIPTION	QTY.
99028	BIPOD YOKE	1
99029	BIPOD ASSEMBLY PIN	1
99030	YOKE MOUNT	2
99031	YOKE MOUNT PIN	2
*99038	BARREL WASHER	1
99039	FIRING PIN LOCK SCREW	1
99043-1	BUTTPATE BACK SCREW	2
99044	BUTTPATE FRONT SCREW	1
99047	ASSEMBLY PIN	3
99048	EJECTOR SPRING	1
99204-C1	TRIGGER HOUSING COMPLETE	1
99206	SEAR PIVOT	1
99208	SEAR PIVOT PIN	1
*99209	SEAR LINK	1
*99217-C	BOLT COMPLETE	1
99221	EJECTOR	1
99246	SCOPE BASE SCREW	5
*99300	RECEIVER	1
*99301	BOLT GUIDE	1
99304	SLING PLATE	1
*99314-C	BARREL COMPLETE .50	1
*99314-C1	BARREL COMPLETE .416	1
*99316	BARREL NUT	1
99330	SCOPE BASE	1
99331	REAR SCOPE BASE SCREW	1
99338	RECOIL PAD SCREW	2
99359	MUZZLE BRAKE, TITANIUM	1

(This page intentionally blank.)

